

**SEE PAGE 11 FOR IMPORTANT INFORMATION CONCERNING LIMITED  
WARRANTY, AND LIMITATION OF LIABILITY**

## INTRODUCTION

The Daniels SCTP Series Pneumatic Safe-T-Cable<sup>®</sup> application tool is designed to crimp ferrules, and tension/cut the cable in accordance with the performance requirements of SAE specification AS4536\*. The application tool installs Safe-T-Cable<sup>®</sup> kits identified in SAE specifications AS3509\*, AS3510\* and AS3511\*.

The following steps are important:

1. Proper tool setting (section 1.0)
2. Proper cable installation (section 2.0)
3. Proper loading and use of the application tool (section 3.0)
4. Verification of proper application (section 4.0)

\* SAE publications are available from:  
SAE, International  
400 Commonwealth Drive  
Warrendale, PA 15096-0001

## 1.0 TOOL MAINTENANCE AND VERIFICATION OF TOOL SETTINGS

### 1.1 Checking Indenter Settings with the Daniels SCT-TB1 Torque Verification Block

- 1.1.1. Indenter settings should be checked periodically and must be checked after the nose assembly has been removed or changed.
- 1.1.2. Thread the cable into the left swivel and through the right swivel, holding the lever in the home position as shown in figure 1. If the lever is not kept in the home position the results may be adversely affected. Terminate the cable per section 3.0.
- 1.1.3. Apply approximately 2 lb force to the cable with your finger (or use the Daniels SCTD013 Retention Tester) at the line marked "TEST AREA". If the cable touches either the side or bottom surface of the test area, remove the cable from the block. Properly terminate another cable, holding the tool perpendicular to the cable and making certain that there is no more than 1 1/2 inch of slack.

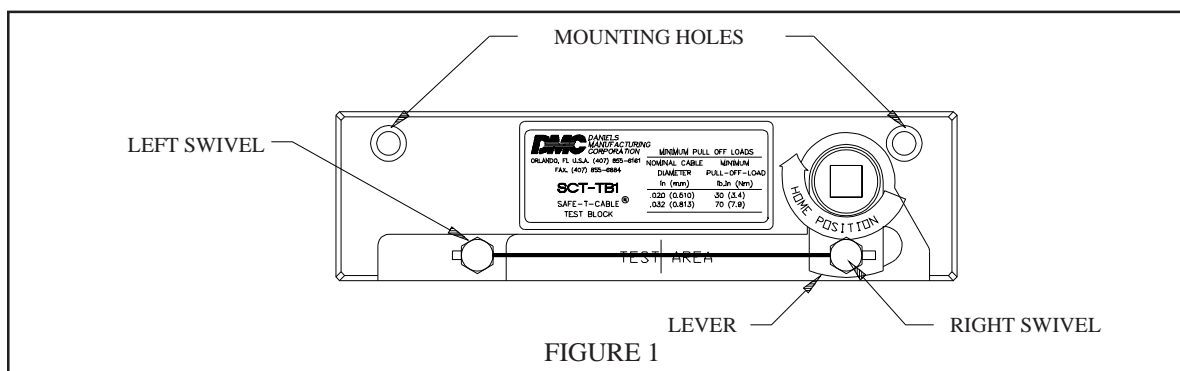

DANIELS MANUFACTURING CORP. 526 THORPE ROAD, ORLANDO, FL 32824, USA  
PHONE (407) 855-6161 • FAX (407) 855-6884 • w ww.DMCTools.com • E-MAIL: DMC@DMCTools.com

- 1.1.4. Place a calibrated 3/8" drive torque wrench (Daniels SCTD0001) into the square drive hole, orienting the torque verification block and torque wrench on a flat surface as shown in figure 2. Apply the proper pull-off load as shown in table 2.

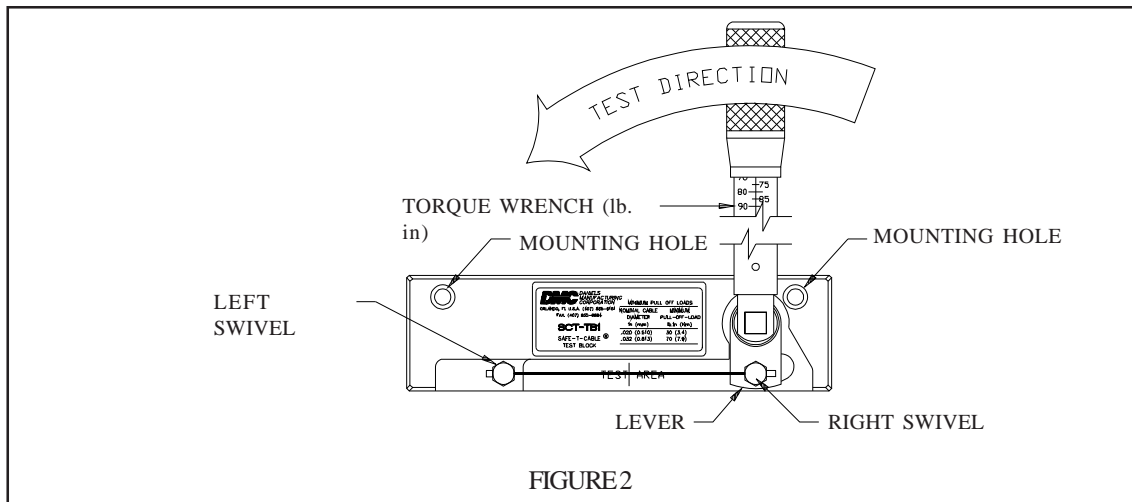

**CAUTION: RELEASE TORQUE WHEN MINIMUM PULL-OFF IS ACHIEVED.  
DO NOT APPLY ADDITIONAL TENSION TO THE CABLE.**

- 1.1.5. If the cable did not break or pull out of the ferrule after applying proper torque, remove the torque wrench and apply approximately 2 lb force to the cable with your finger (or Daniels SCTD013) at the line marked "TEST AREA".
- 1.1.6. If the cable breaks or pulls out of the ferrule, or it touches either the side or bottom surface of the test area, then the crimp is unacceptable and the tool indenter should be adjusted per section 1.2.

## 1.2 INDENTER ADJUSTMENT

- 1.2.1. Remove the nose assembly by removing the two 8-32 socket head cap screws as shown in figure 3.
- 1.2.2. Loosen the pushrod lock-nut using the SCT32084 adjustment tool as shown in figure 4A.

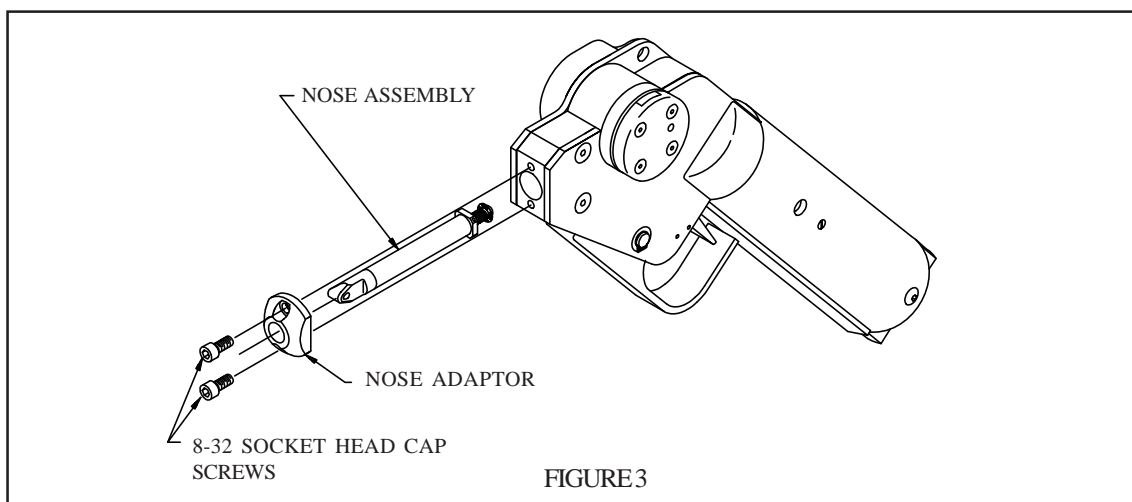

- 1.2.3. Adjust the pushrod screw using a screwdriver and SCT32084 Adjustment Tool as shown in figure 4B. Turn the pushrod adjustment screw clockwise to loosen the crimp (enlarge the gaging dimension). Turn the pushrod adjustment screw counterclockwise to tighten the crimp (reduce the

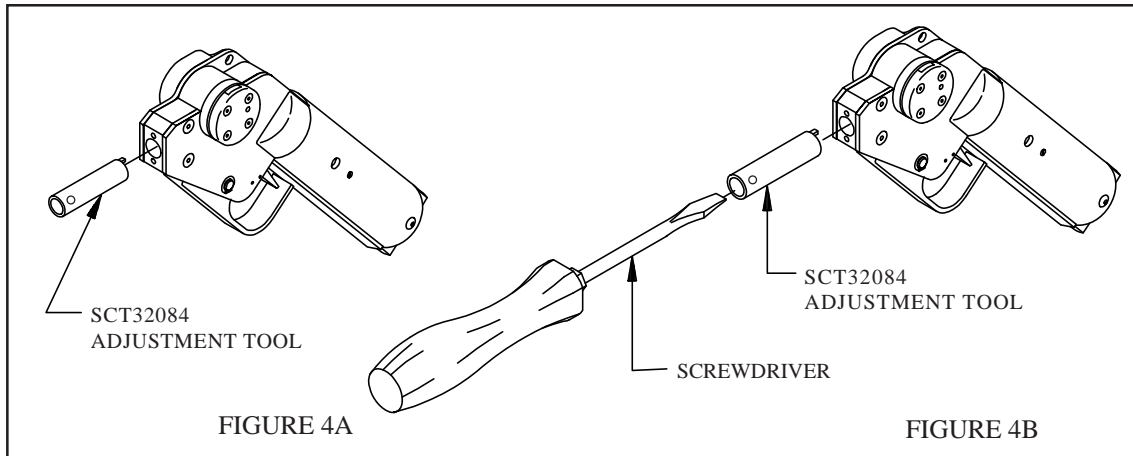

gaging dimension).

- 1.2.4. Tighten the pushrod lock-nut using the SCT32084 adjustment tool as shown in figure 4A. Replace the nose assembly and the two 8-32 socket head cap screws. Prevent binding by alternately turning each screw a small amount until tight.
- 1.2.5. Check settings as described in section 1.1.

**CAUTION: DO NOT ADJUST THE PUSHROD MORE THAN A QUARTER OF A TURN AT A TIME. SEVERE ADJUSTMENT MAY DAMAGE THE TOOL.**

### 1.3. RELEASING THE INDENTER

- 1.3.1. The SCTP series pneumatic Safe-T-Cable<sup>®</sup> tool has an internal cycle control feature which prevents the indenter from returning if the crimping cycle is not completed. Therefore, if the air pressure is insufficient or the tool is adjusted too tight, the tool may not complete the crimp cycle and the indenter may not release the ferrule.
- 1.3.2. To release the indenter, loosen the two 8-32 socket head cap screws which retain the nose (see figure 3). Activate the tool.
- 1.3.3. After the indenter has returned, tighten the 8-32 socket head cap screws as described in 1.2.4. above.

### 1.4 ADJUSTING THE TENSION

- 1.4.1. Adjust cable tension using a screwdriver as shown in figure 5. Turning the tension adjustment screw clockwise increases cable tension. Turning the tension adjustment screw counterclockwise decreases cable tension. Proper cable tension is defined in section 4.0, the lowest cable tension setting which meets the requirements of section 4.0 should be used.

**CAUTION: WHEN USING .020 CABLES NOT MANUFACTURED BY DMC, VERIFY TENSILE VALUES USING THE SCT-TBI TORQUE VERIFICATION BLOCK AS DESCRIBED IN SECTION 1.0 AFTER INCREASING CABLE TENSION.**

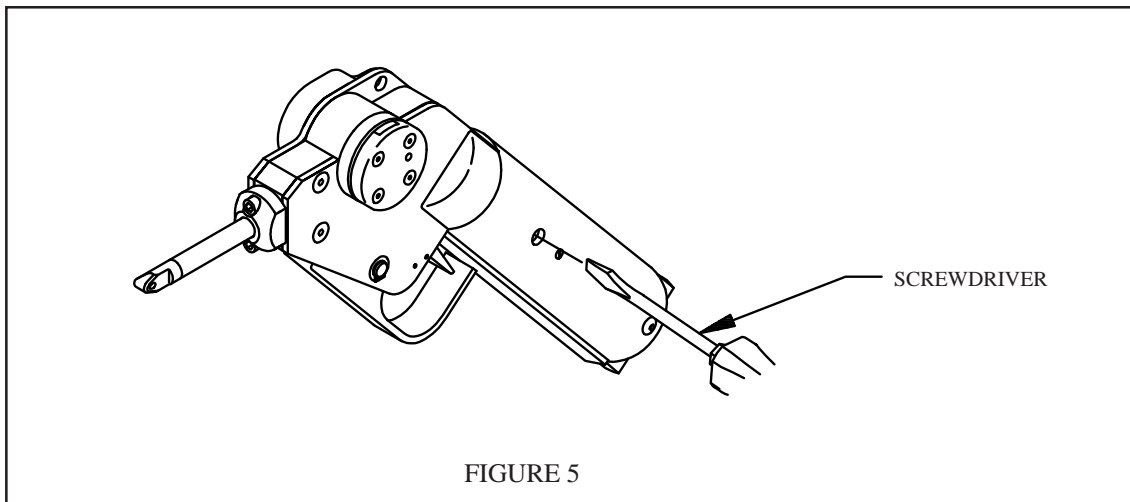

## 1.5 MAINTENANCE OF THE CRIMP CAVITY

- 1.5.1. Debris can accumulate in the crimp cavity during use. This debris must be removed and the cavity oiled periodically depending upon use and environment. **Ferrule sticking can occur if this procedure is not followed.**
- 1.5.2. Remove debris by gently scraping or brushing the crimp cavity. Blow any remaining debris from the cavity with air.
- 1.5.3. **Coat the cavity with a light film of any lightweight synthetic or petroleum based oil after the cavity has been thoroughly cleaned.**

## 2.0 PROPER CABLE INSTALLATION

- 2.1 Various examples of Safe-T-Cable<sup>®</sup> installation are shown in figures 6 through 8. Although all possible combinations are not shown, three basic rules apply:
  - A) It is recommended that Safe-T-Cable<sup>®</sup> be installed in such a manner that any tendency for a fastener to loosen will be counteracted by an additional tension on the cable. Sharp turns in excess of 135° should be avoided. Installed Safe-T-Cable<sup>®</sup> should produce a positive or neutral pull on the fastener.
  - B) Safe-T-Cable<sup>®</sup> should be installed in two or three bolt patterns. Two bolt patterns being preferred when Safe-T-Cable<sup>®</sup> is applied to an even number of fasteners.
  - C) Maximum span of Safe-T-Cable<sup>®</sup> shall be six inches from end to end.

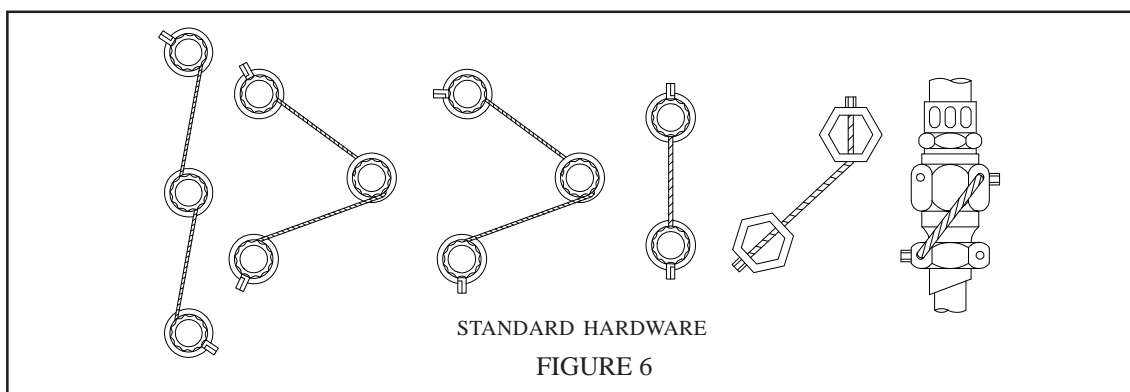

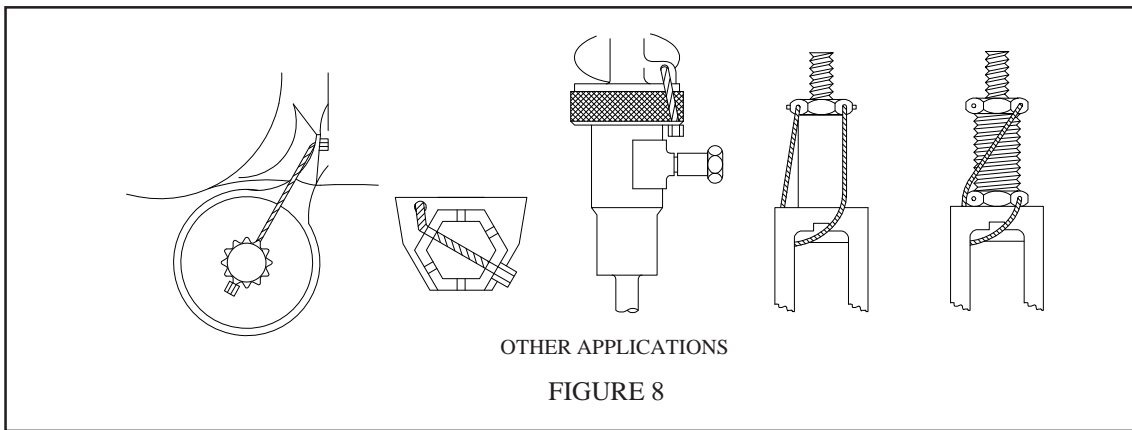
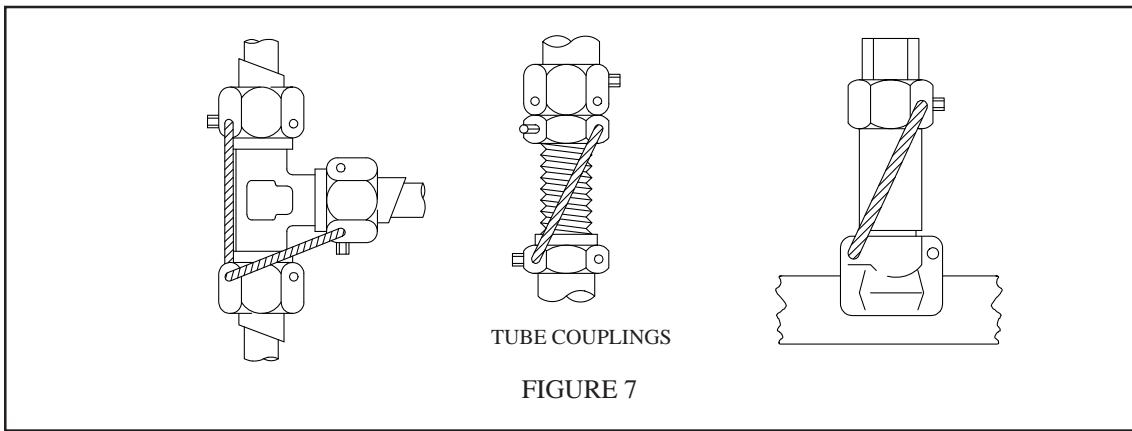

### 3.0 PROPER LOADING AND USE OF THE APPLICATION TOOL

- 3.1. Connect the tool to a clean, dry air supply of 110 to 120 psi.
- 3.2. Install the Safe-T-Cable<sup>®</sup> through the fasteners as described in section 2.0
- 3.3. The nose can rotate to any position (see figure 9). Rotate the nose to the desired position.

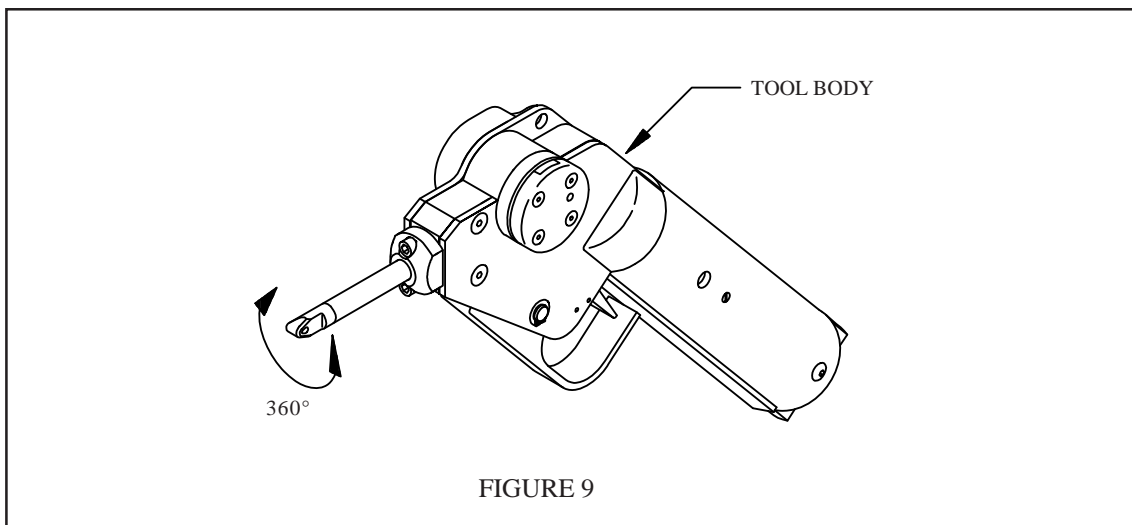

- 3.4 Insert the free end of the cable through the last ferrule in the cartridge as shown in figure 10. Remove the ferrule by pulling the cable away from the end of the cartridge.

**CAUTION: DO NOT RELEASE THE FREE END OF THE CABLE UNTIL IT HAS BEEN INSERTED THROUGH THE NOSE.**

- 3.5 Insert the free end of the cable through the nose as shown in figure 11. Slide the tool along the cable to the desired position.
- 3.6 Rotate the cable tensioning wheel with the cable entry slot up to the position shown in figure 12. Position the nose such that the ferrule is pressed squarely against the fastener. Make certain that the ferrule is fully seated in the nose.
- 3.7 Insert the free end of the cable into the cable entry slot of the cable tensioning wheel. When the free end of the cable appears at the bottom of the wheel, grab the cable and pull slack from the cable. Do not leave more than 1 1/2" of slack in the cable (figure 13).

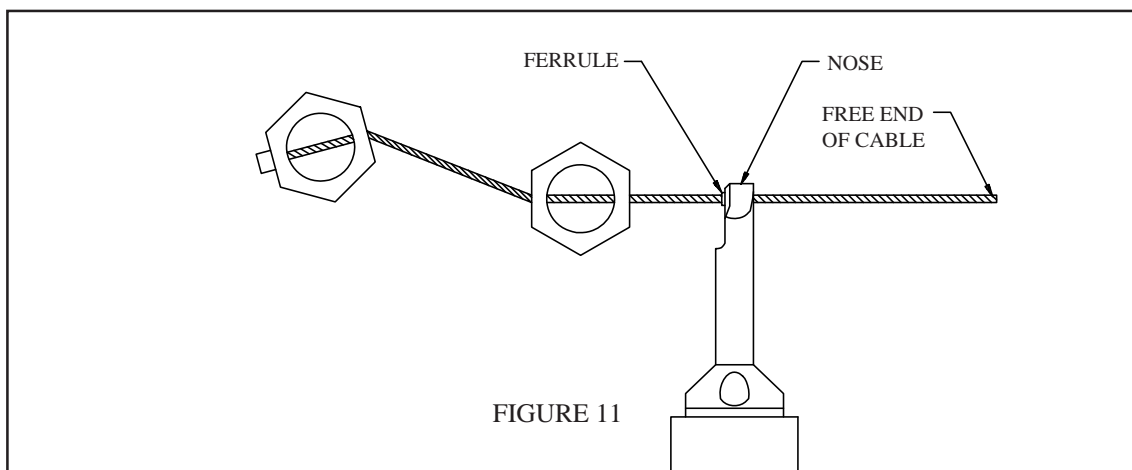
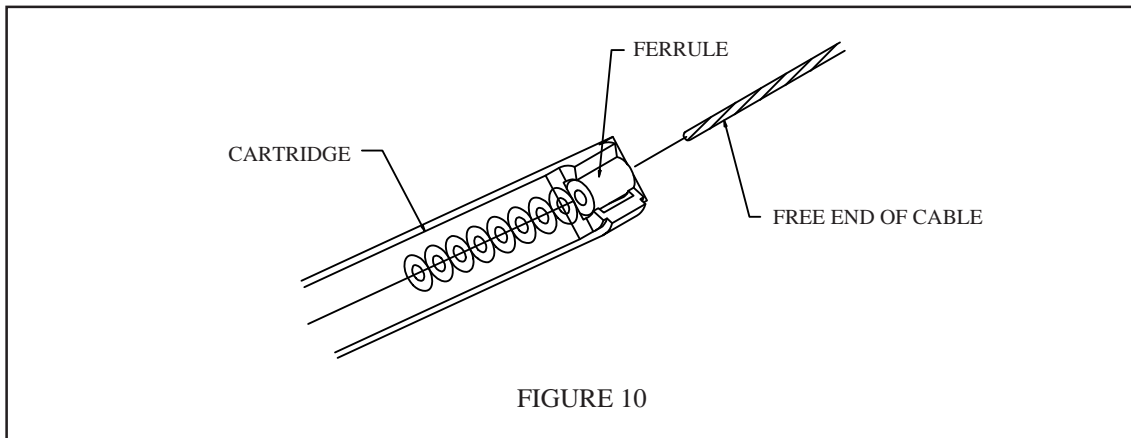

- 3.8 Press the trigger and hold.

**CAUTION: IT IS IMPORTANT TO HOLD THE TOOL STEADY AND PERPENDICULAR TO THE CABLE DURING THE CRIMPING CYCLE TO MAINTAIN CONSISTENT TENSION (FIGURE 12).**

- 3.9 After crimping and cutting, release the trigger and slide the tool off the crimped ferrule. Pull the excess cable from the tool.

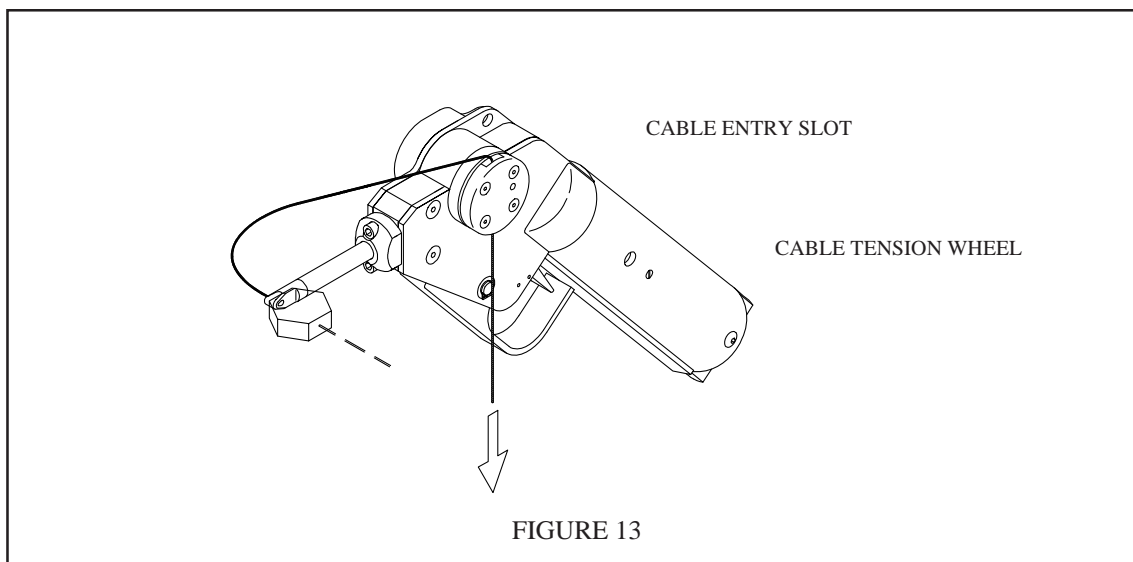
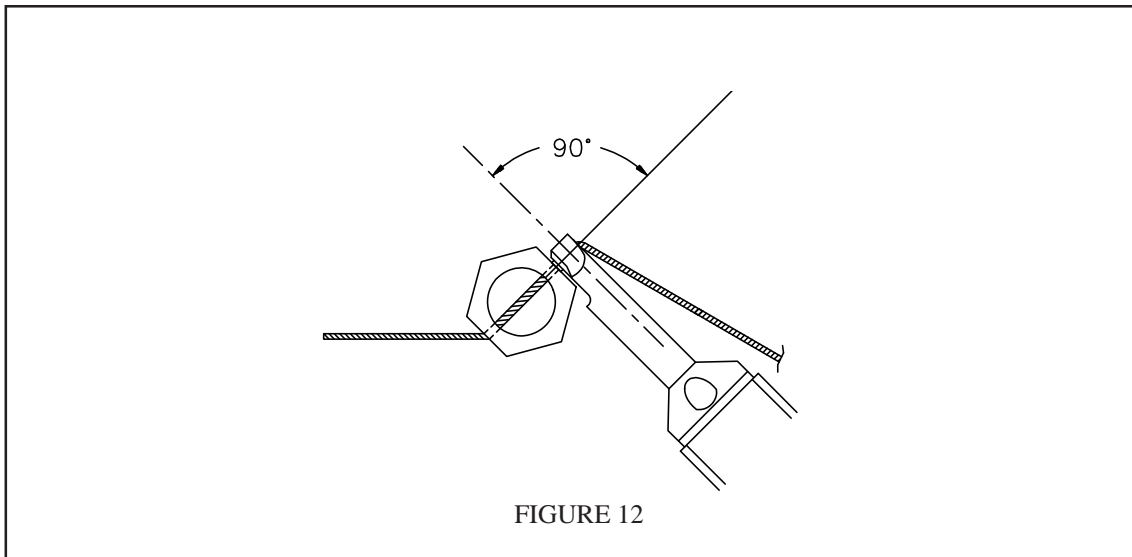

#### 4.0 VERIFICATION OF INSTALLATION

- 4.1 Verify proper tension of the cable. Refer to table 1, figure 14 for Safe-T-Cable<sup>®</sup> flex limits.
- 4.2 Verify that the cable was installed through the bolts in accordance with section 2.0
- 4.3 Verify that the cable was cut flush at the end of the ferrule with no strand extending more than 1/32 inch from the end of the ferrule.
- 4.4 Visually inspect the cable for any nicks or other damage that may have occurred during installation.

TABLE 1 - FLEX LIMITS, DIMENSIONS		
A inch (mm)	B inch (mm)	C inch (mm)
0.5 (12.7)	0.125 (3.18)	0.062 (1.59)
1.0 (25.4)	0.250 (6.35)	0.125 (3.18)
2.0 (50.8)	0.375 (9.52)	0.188 (4.76)
3.0 (76.2)	0.375 (9.52)	0.188 (4.76)
4.0 (101.6)	0.500 (12.70)	0.250 (6.35)
5.0 (127.0)	0.500 (12.70)	0.250 (6.35)
6.0 (152.4)	0.625 (15.88)	0.312 (7.94)

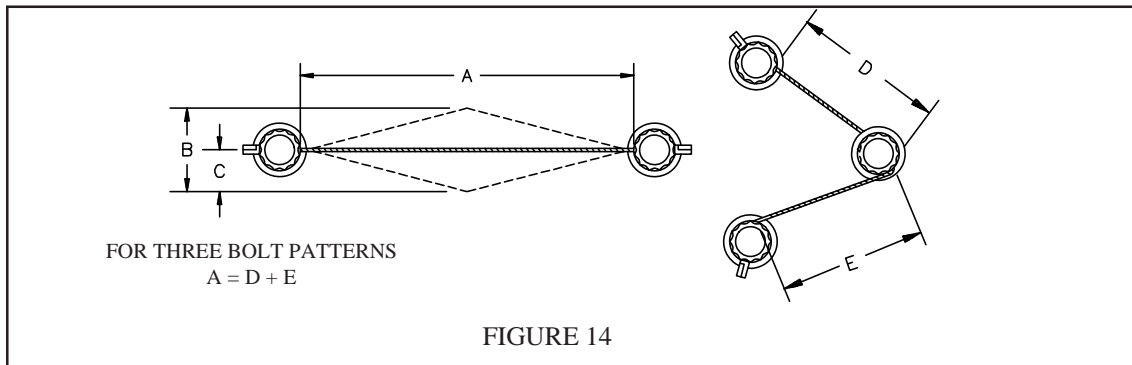

## 5.0 SAFE-T-CABLE® SYSTEM PART NUMBERS

### 5.1 Tool/Accessory part numbers:

HAND APPLICATION TOOLS		
TOOL PART NUMBER	NOMINAL CABLE DIAMETER	NOSE LENGTH
SCT203	.020	3 INCHES
SCT207	.020	7 INCHES
SCT323	.032	3 INCHES
SCT327	.032	7 INCHES
SCT403	.040	3 INCHES
SCT407	.040	7 INCHES

PNEUMATIC APPLICATION TOOLS		
TOOL PART NUMBER	NOMINAL CABLE DIAMETER	NOSE LENGTH
SCTP203	.020	3 INCHES
SCTP207	.020	7 INCHES
SCTP323	.032	3 INCHES
SCTP327	.032	7 INCHES
SCTP403	.040	3 INCHES
SCTP407	.040	7 INCHES

INTERCHANGEABLE NOSES		
NOSE PART NUMBER	NOMINAL CABLE DIAMETER	NOSE LENGTH
SCTN20-3	.020	3 INCHES
SCTN20-7	.020	7 INCHES
SCTN32-3	.032	3 INCHES
SCTN32-7	.032	7 INCHES
SCTN40-3	.040	3 INCHES
SCTN40-7	.040	7 INCHES

TOOL VERIFICATION TOOLS	
TOOL PART NUMBER	DESCRIPTION
SCT-TB1	TORQUE VERIFICATION BLOCK
SCTD0001	TORQUE WRENCH (20-150 LB IN)
SCTD013	RETENTION TESTER

SAFE-T-CABLE® DIAGONAL CUTTERS
45 - 6N

All sizes and lengths are interchangeable using the same basic tool. Indenter settings must be checked whenever the nose is changed. See section 1.1.

## 5.2 SAE to DMC part number cross reference

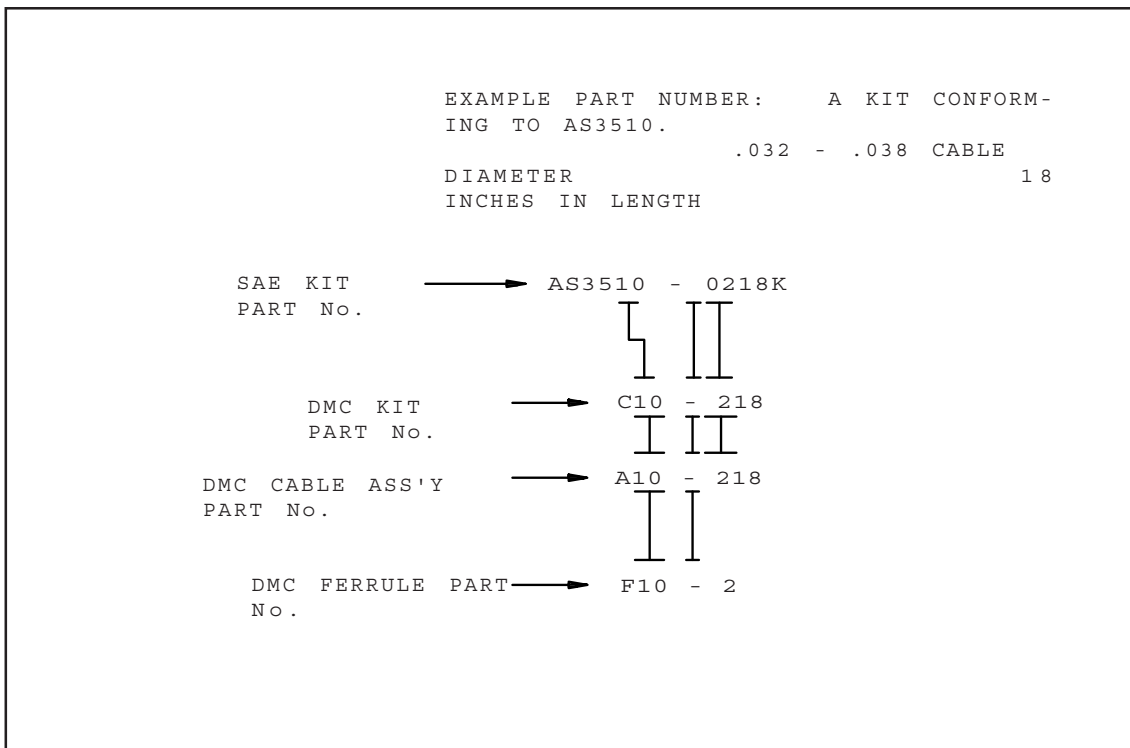
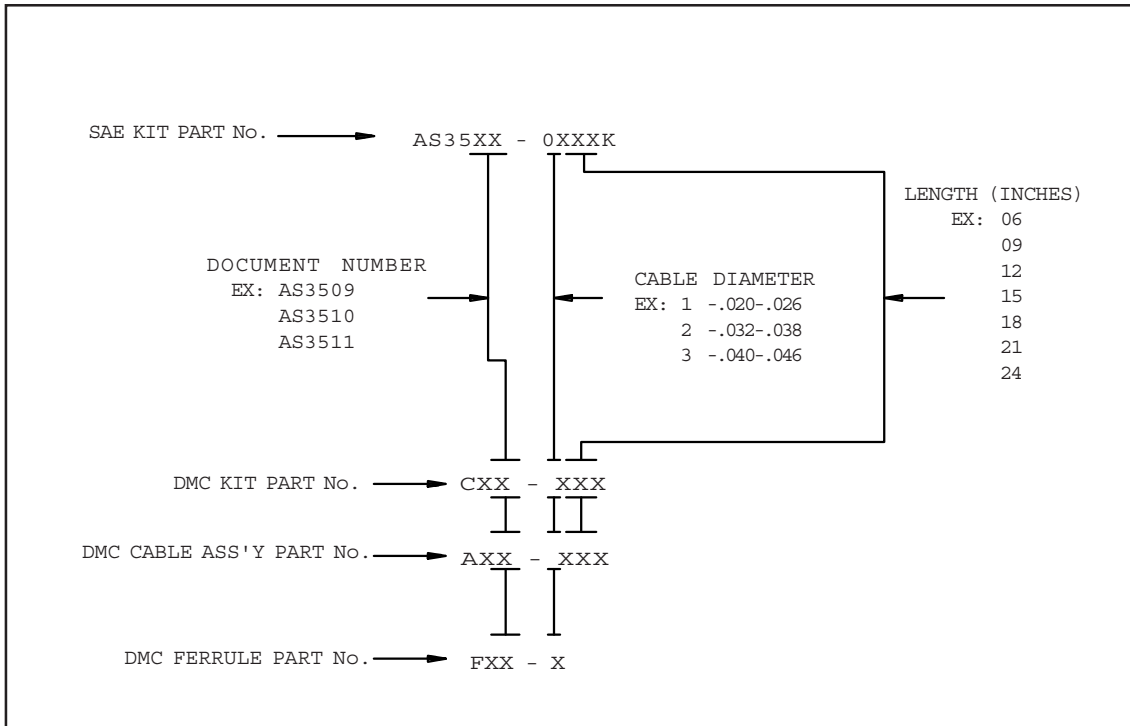

### 5.3 Daniels Safe-T-Cable® Kit part numbers\*

TABLE 2 - .020, .032, .040 NOMINAL DIAMETER CABLE KITS				
KIT PART NUMBER	(D) CABLE DIAMETER	COMPONENT MATERIAL	(L) LENGTH (INCHES)	MINIMUM PULL-OFF LOAD lbf (N)
C10-106	.020 - .026 (1 x 7 CABLE)	UNS S32100 CORROSION AND HEAT RESISTANT ALLOY (AMS5689)	6	30 (133.4)
C10-109			9	
C10-112			12	
C10-115			15	
C10-118			18	
C10-121			21	
C10-124			24	
C10-206	.032 - .038 (3 x 7 CABLE)	UNS S32100 CORROSION AND HEAT RESISTANT ALLOY (AMS5689)	6	70 (311.4)
C10-209			9	
C10-212			12	
C10-215			15	
C10-218			18	
C10-221			21	
C10-224			24	
C10-306	.040 - .046 (7 x 7 CABLE)	UNS S32100 CORROSION AND HEAT RESISTANT ALLOY (AMS5689)	6	110 (489.3)
C10-309			9	
C10-312			12	
C10-315			15	
C10-318			18	
C10-321			21	
C10-324			24	

\* A Safe-T-Cable® kit includes cable with an end fitting attached, and a ferrule. Kits are sold and packaged in groups of 50.

### 5.4 Daniels Safe-T-Cable® Assembly part numbers\*\*

TABLE 3 - .020, .032, .040 NOMINAL DIAMETER CABLE ASSEMBLIES				
KIT PART NUMBER	(D) CABLE DIAMETER	COMPONENT MATERIAL	(L) LENGTH (INCHES)	MINIMUM PULL-OFF LOAD lbf (N)
A10-106	.020 - .026 (1 x 7 CABLE)	UNS S32100 CORROSION AND HEAT RESISTANT ALLOY (AMS5689)	6	30 (133.4)
A10-109			9	
A10-112			12	
A10-115			15	
A10-118			18	
A10-121			21	
A10-124			24	
A10-206	.032 - .038 (3 x 7 CABLE)	UNS S32100 CORROSION AND HEAT RESISTANT ALLOY (AMS5689)	6	70 (311.4)
A10-209			9	
A10-212			12	
A10-215			15	
A10-218			18	
A10-221			21	
A10-224			24	
A10-306	.040 - .046 (7 x 7 CABLE)	UNS S32100 CORROSION AND HEAT RESISTANT ALLOY (AMS5689)	6	110 (489.3)
A10-309			9	
A10-312			12	
A10-315			15	
A10-318			18	
A10-321			21	
A10-324			24	

\*\* A Safe-T-Cable® assembly consist of a cable with an end fitting attached. Assemblies are sold and packed in groups of 50.

**5.5 Daniels Safe-T-Cable® ferrule part numbers**

<b>TABLE 4 - FERRULES</b>		
FERRULE PART NUMBER	FOR NOMINAL CABLE DIAMETER	MATERIAL
F10-1	.020	UNS S32100
F10-2	.032	UNS S32100
F10-3	.040	UNS S32100

Daniels ferrules are sold in groups of 50 and are packaged in a cartridge.

<b>TABLE 5 - ELONGATED FERRULES FOR LOW PROFILE APPLICATIONS</b>		
FERRULE PART NUMBER	FOR NOMINAL CABLE DIAMETER	MATERIAL
F10-08	.020	UNS S32100
F10-04	.032	
F10-07	.040	

Consult factory for information concerning low profile installations.

**INVALIDATION OF LIMITED WARRANTY**

This manual is provided to those owners of Daniels Manufacturing Corporation (DMC) products who have elected to conduct in-house repairs of such products and who thereby consent to waive any rights which they otherwise might have had under the DMC limited warranty applicable to such products.

DMC provides complete repair and maintenance service for all of its products. Owners of DMC products are warned that any tampering, including partial or complete disassembly of the product or attempted repairs of the product will invalidate the limited warranty applicable to said product.

**LIMITATION OF LIABILITY**

Daniels Manufacturing Corporation (DMC) is not liable for consequential or special damages of any nature or kind resulting from the use, or misuse, of any of its products. Owners and users of (DMC) products assume full responsibility for instructing their employees in the proper and safe use of such products.

**LIMITED WARRANTY**

Daniels Manufacturing Corporation (DMC) warrants each new product sold by it to be free from defects in material and workmanship under normal use and service. DMC's obligation under this warranty is limited to the free correction or, at DMC's option, the refund of the purchase price of any such product which proves defective in normal service within ninety (90) days after delivery to the first user, provided that the product is returned to DMC with all transportation charges prepaid in which shall appear to DMC's satisfaction, after DMC's inspection, to have been defective in material or workmanship, it being understood that DMC products are not consumer products. This warranty shall not cover any damage to any product which, in the opinion of DMC, was caused by normal wear, misuse, improper operation, tampering, neglect or accident. This warranty is in lieu of all other warranties express or implied. No warranty, express or implied, is made or authorized to be made or assumed with respect to products of Daniels Manufacturing Corporation other than those herein set forth.